



CP2-MM

ControlPROLink

Add-on multimedia module for CP2-UNI

PROVIDES MULTIMEDIA OUTPUTS FOR AFTERMARKET RADIOS



ControlPROLink

Add-on multimedia module for CP2-UNI

Introduction

The CP2-MM is a universal module that provides multimedia outputs for aftermarket radios when used in conjunction with a CP2-UNI steering control interface.

The CP2-MM is a plug and play solution that connects to the CP2-UNI with a simple click and translates the vehicle data bus into the required analogue multimedia outputs when installing an aftermarket AV or navigation radio.

What's in the box

- ▶ CP2-MM Multimedia Interface
- ▶ CP2-MM-HAR Harness Adaptor
- ▶ CP2-MM-OUT Harness Adaptor
- ▶ User Guide

Key Features

- ▶ Universal Add-on multimedia module
- ▶ Adds additional functions to the CP2 steering control range
- ▶ Provides up to 5 additional outputs: Handbrake, Illumination, Reverse Signal, Speed Signal & RPM

*CP2-UNI requires firmware version 14.0 or above. Outputs available vary by vehicle. Please refer to the application guide at autoleads.co.uk/controlpro

ControlPROLink

Add-on multimedia module for CP2-UNI

Interface & Wiring Overview

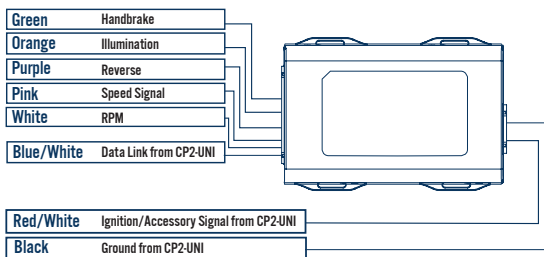
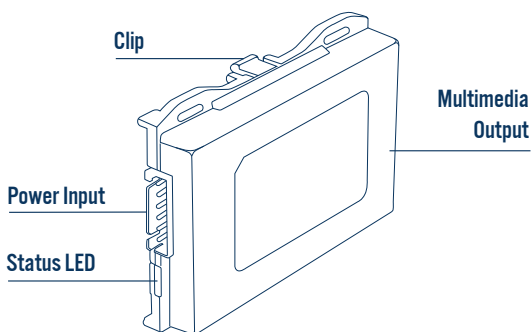

ControlPROLink

Add-on multimedia module for CP2-UNI

Installation

Refer to the application guide at autoleads.co.uk/controlpro for vehicle compatibility.

The CP2-MM connects to the CP2-UNI with a simple click. The enclosure clips secure the modules together through the cable tie slots on the plastic housing. Additional securing slots are provided on the housing of the CP2-MM.

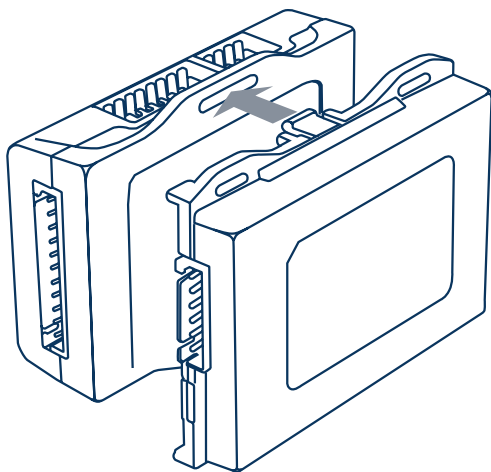

ControlPROLink

Add-on multimedia module for CP2-UNI

Interface & Wiring Overview

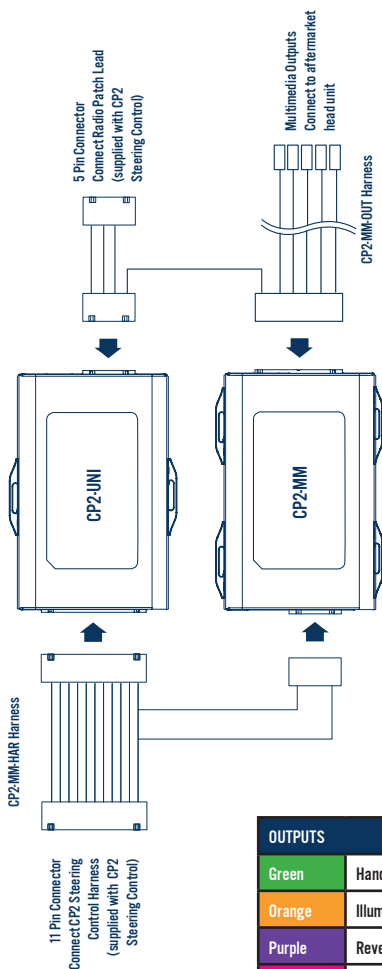

OUTPUTS	
Green	Handbrake
Orange	Illumination
Purple	Reverse
Pink	Speed Signal
White	RPM

ControlPROLink

Add-on multimedia module for CP2-UNI

Testing & Troubleshooting

The CP2-MM is fitted with a tri-coloured LED which can be used to identify the operation. Please refer to the below chart if the CP2-MM is not functioning as expected.

LED Legend		
Colour	Status	Solution
Green	Communication OK	N/A
Amber	No Communication from CP2-UNI	Check Harness and/or Configuration of CP2-UNI as software might need updating to v14 or newer
Flashing Green	Output Changing State	N/A
Flashing Red	MM data ERROR	Check BLUE/WHITE data wire or relocate module
Flashing Amber	Communication Frame ERROR	Check BLUE/WHITE data wire or relocate module

ControlPROLink

Add-on multimedia module for CP2-UNI

NOTES:



email - technical.eu@aampglobal.com
autoleads.co.uk

Autoleads is a Power Brand of AAMP Global.