

SSM-RBP
SSM-DIS



**Parking Sensor System
with Buzzer or Display
User Manual**



ECHOMASTER

Installation Guide



SSM-RBP / SSM-DIS

Parking Sensor System
with Buzzer or Display

Introduction

Congratulations on purchasing EchoMaster parking sensors. This ultrasonic detection system is designed for you and your vehicle's safety.

Disclaimer:

EchoMaster® is strictly a driver assistance device, and should not be relied upon as a substitute for safe driving practices. Use common sense when parking and always follow recommended safe driving guidelines from your local, State and County Department of Motor Vehicles regarding parking procedures. To help prevent accidents, always use caution when parking, looking visually to ensure your path is clear. Keep speeds under three miles per hour. The owner shall not be entitled to recover from the Company, its successors or assignees, incidental and consequential damages, such as personal injury, loss of income, loss of time, loss of profits, loss of vehicle use or property damage. No employee, agent or representative of the Company of the Selling Retailer may modify alter or extend this Warranty in any way. This Warranty gives you specific legal rights. You may also have other rights under this Warranty which may vary from state to state.

Note: Under no circumstances should you attempt to open the control box or any other component. Doing so will void all manufacturer's warranties.

This manual covers the following products:

SSM-DIS Sensor Module with Display - Front/Rear
SSM-RBP Rear Sensor Module with Buzzer

These products are to be used with any of the following:

SEN-XX Colored Sensors to match your vehicle
SEN-MB Sensors made for metal bumpers
SEN-FM Flush Mount sensors for OEM look

Box Contents

- ▶ Buzzer (SSM-RBP only)
- ▶ Display (SSM-DIS only)
- ▶ Override Button (SSM-DIS only)
- ▶ Sensor Module
- ▶ Power Harness
- ▶ Data cable (SSM-DIS only)
- ▶ Installation Accessories
- ▶ Warranty Card
- ▶ Installation Guide

Key Features

- ▶ Customizable sensor kit to fit your application
- ▶ Digital LED Display (SSM-DIS only)
- ▶ Adjustable volume control buzzer (SSM-RBP only)
- ▶ Fully automatic operation
- ▶ Buzzer silence with no movement detection
- ▶ Speed dependent automatic power on for front camera

SSM-RBP / SSM-DIS

Parking Sensor System
with Buzzer or Display



Fitting Instructions

The sensors should ideally be equally spaced along the bumper. For best results we recommend that the outer sensors are spaced between 8-13cm from the edge of the bumper.

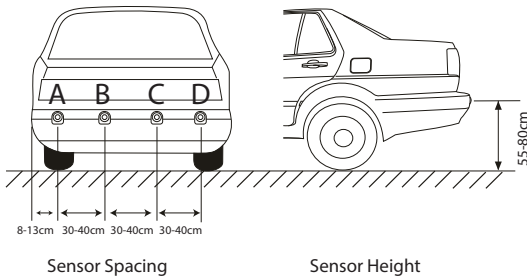

The sensors should then be spaced between 30-40cm from each other as shown in the diagram.

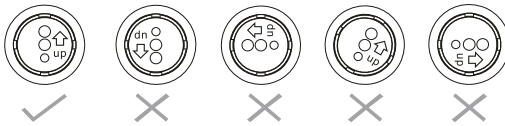

Sensor Orientation

Please note the orientation arrow on the sensors as shown. This should be pointing up for the sensors to work correctly.

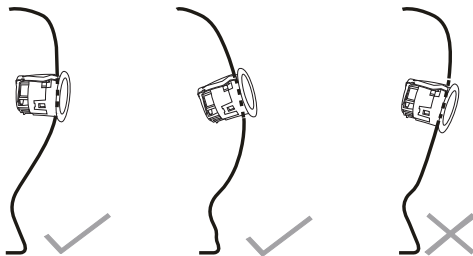

Parallel or Upwards Angle Mounting

Please also be aware that the sensors should be mounted parallel to the ground or slightly upwards facing. They should under no circumstances be angled downwards.

Installation Guide



SSM-RBP / SSM-DIS

Parking Sensor System
with Buzzer or Display

Wiring Diagrams

Please reference the following wiring diagrams & information for various installation

SSM-RBP

Red - Connect to a +12V switched ignition supply.

Black - Connect to ground.

Yellow - Connect to +12V switched reverse wire.

Blue - Not connected.

White - Not connected.

Grey - Only used when combining 2 kits into a complete front and rear installation - joining both modules together.

2 Pin Plug - Connect to the supplied buzzer.

PLEASE NOTE

The sensors are labelled A, B, C and D for both modules. Please ensure that these are plugged into the corresponding ports on the module.

SSM-DIS

Red - Connect to a +12V switched ignition supply.

Black - Connect to ground.

Yellow - Only used in rear mode - Connect to +12V switched reverse wire.

Blue - Not connected in rear mode. In front mode, connect to the supplied switch and connect the other side of the switch to +12V IGN.

White - Not connected in rear mode. In front mode, connect this wire to the vehicle analog speed pulse wire (this can often be found behind the radio or the instrument cluster).

Grey - Only used when combining 2 kits into a complete front and rear installation - joining both modules together.

2 Pin Plug - Not used in rear mode. In front mode, the black wire of this plug can be used to trigger a camera or other device to automatically turn on below the set speed (+12V output).

Installation Guide

SSM-RBP / SSM-DIS

Parking Sensor System
with Buzzer or Display



SSM-RBP

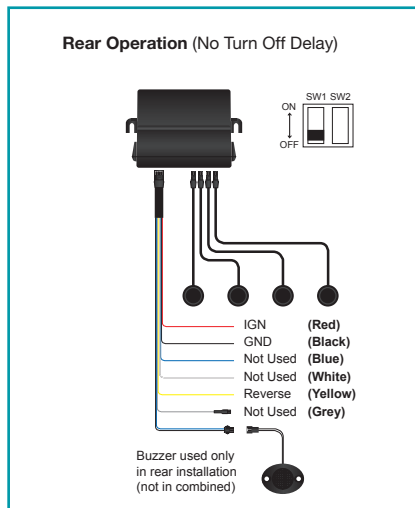
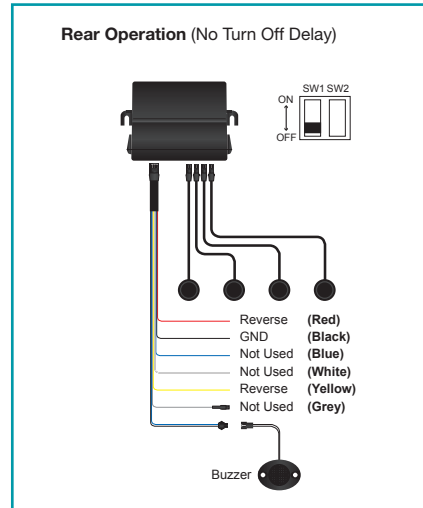
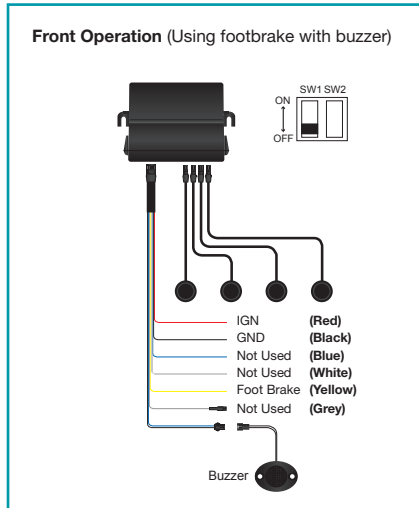

Installation Guide



SSM-RBP / SSM-DIS Parking Sensor System with Buzzer or Display

SSM-DIS

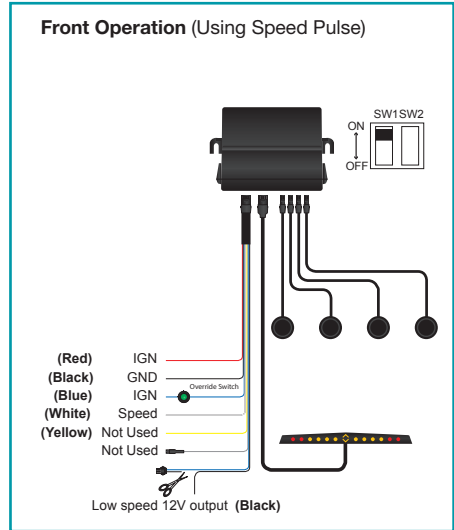
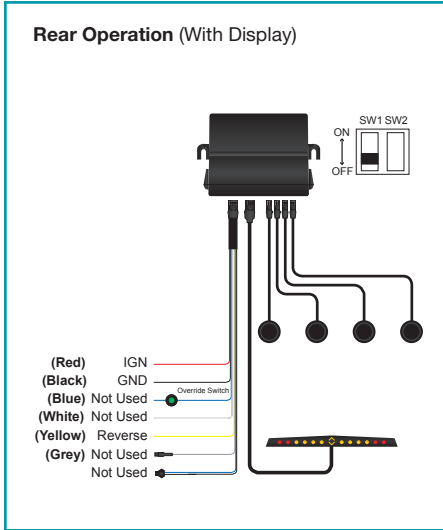

Front & Rear Operation

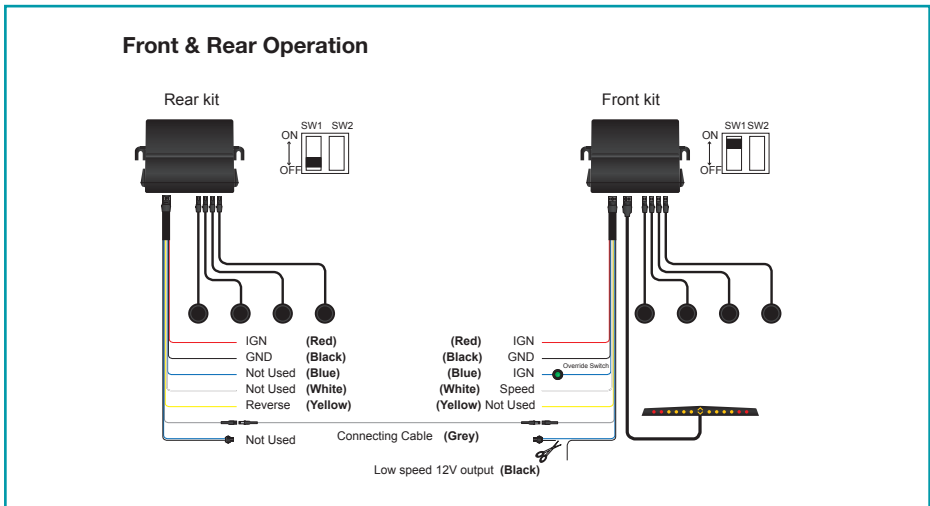

SSM-RBP / SSM-DIS

Parking Sensor System
with Buzzer or Display



Setting Up

Dip switches

The dip switches should be set as follows:

Dip switch 1

This determines whether the kit is being used in front or rear mode.

▶ **Up (ON)** – Front mode

▶ **Down (OFF)** – Rear mode

Dip switch 2

This adjusts the detection range by 20cm when the kit is in rear mode to allow for vehicles with tow-bars or other rear protrusions. Please note that this function does not ignore the protrusion (this is unnecessary if the sensor spacing is correct) but it moves the object detection alerts 20cm further away from the back of the vehicle. This results in the continuous tone being heard 20 cm earlier than usual to account for the extra length of the protrusion.

▶ **Up (ON)** – Distance adjustment on.

▶ **Down (OFF)** – No distance adjustment

PLEASE NOTE

Dip switch 2 has no function when the kit is placed in front mode.

Speed Sensor Setting

When in front mode, the speed sensor requires calibration before it can work correctly. To accomplish this, drive the vehicle at the desired shut off speed and then press and hold the button on the display for 3 seconds and then release. The two arrows on the display should now flash.

If the speed signal has been recognised correctly the display will beep after a few seconds and all the LEDs will light up briefly.

Once set up the kit will not function above this speed.

This signal also allows the switched output to be active below this speed (for camera or other device automatic turn on).

Installation Guide



SSM-RBP / SSM-DIS

Parking Sensor System
with Buzzer or Display

Operation

Upon first powering the system it will perform a self check of all sensors.

If any sensors are faulty then the display will flash to show which sensor is malfunctioning. Each set of 3 LEDs correspond to one sensor so if any group of 3 flashes it means that sensor is faulty. It will also signify whether this is front or rear by use of the arrows on the display.

Please see the drawing below for fault detection indicators.

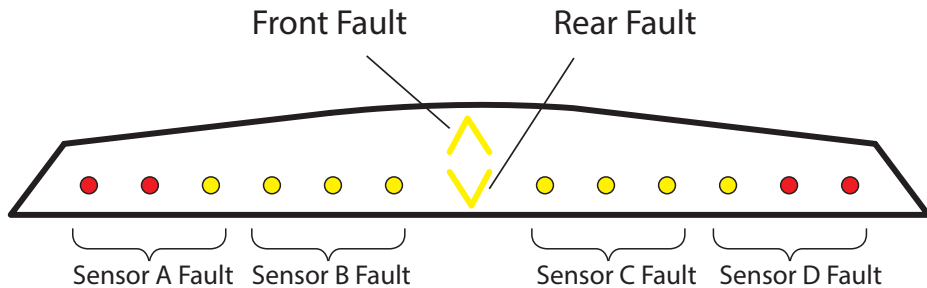

Rear Application

For rear applications, **SSM-DIS** or **SSM-RBP** can be used.

When reverse is engaged, the system will beep once to notify the driver it is on and working. When an object is within range, the driver will be alerted via audible and/or visual alert (if using the display).

SSM-RBP / SSM-DIS

Parking Sensor System
with Buzzer or Display



Front Application

For front applications, **SSM-DIS** must be used.

This system is fully automatic. It is on when the vehicle ignition is on. It is active when the vehicle is below the set speed and is in standby mode when the vehicle is above the set speed. The system should beep once when powered on to notify the driver that it is on and working.

When the unit detects an obstruction the display (SSM-DIS only) will illuminate.

Additionally, as the obstruction gets closer the user will be alerted via a series of beeps that will increase in frequency together with more segments being illuminated on the display.

The display will also show which side the object is (left or right) by using that sides corresponding LEDs. Depending on whether the obstruction is at the front or the rear of the vehicle the corresponding arrow will illuminate on the display. The top arrow signifies a front obstruction and the lower one a rear. If an obstruction is present at both the front and rear of the vehicle then the display will alternate between the two.

If no movement is detected for 2 seconds then the audible alert will be muted but the visual alert will remain active. If movement is then detected again, audible and visual alerts will resume.

To turn off the alerts press the external override button once. To reactivate, press the button again. This feature can be useful in stop start traffic to avoid unnecessary alerts. The kit will reset to standby mode once the vehicle has surpassed the set

Combined Application

If combining 2 kits into a complete front and rear parking solution then the buzzer does not need to be installed as both kits will work with the one single display which includes a buzzer. This buzzer can be turned off by briefly pressing the button on the back of the display.

Operation will be as per the individual front and rear applications.

Note that when combining 2 modules into a complete kit, one of those modules must include a display (SSM-DIS).

Installation Guide



SSM-RBP / SSM-DIS

Parking Sensor System
with Buzzer or Display

Specification

SSM-RBP / SSM-DIS	
Operating Voltage Range	10.5 - 16V DC
Rated Voltage	12-24V DC
Rated Current	30-280mA
Operating Temperature	-30 - +70C
Waterproof Grade (Sensors & Module)	Sensors: IP67 - Module: IP40
Detection Range	Front: 0.2-0.7m - Rear: 0.2-1.5m
Ultrasonic Frequency	40KHz
Hole Saw	Hole Saw included in SEN-XX

Installation Guide

SSM-RBP / SSM-DIS

Parking Sensor System
with Buzzer or Display



Installation Guide



SSM-RBP / SSM-DIS

Parking Sensor System
with Buzzer or Display

Installation Guide

SSM-RBP / SSM-DIS

Parking Sensor System
with Buzzer or Display





15500 Lightwave Drive, Suite 202, Clearwater, Florida 33760
Woolmer Way, Bordon, Hampshire, United Kingdom

email - support@aampglobal.com (US)
tel - 1-800-477-2267 (East Coast) - 1-888-883-2790 (West Coast)

email - technical.eu@aampglobal.com (Europe)



EchoMaster is a Power Brand of AAMP Global.
EchoMaster.com

SSM-RBP / SSM-DIS_v2060318