

PCAM-110



## Lip or Trunk Handle Mount Camera User Manual



## Introduction

Thank you for purchasing your EchoMaster Pro automotive camera.

This manual covers the following part numbers

- ▶ PCAM-110-P
- ▶ PCAM-110-N

EchoMaster Pro cameras are designed to improve safety during driving by providing high quality images of surrounding areas and obstacles in the vicinity of the vehicle. They will also improve vehicle maneuvering capability by displaying blind spots not normally visible to the driver.

Please ensure you read and understand all aspects of this manual before fitting or using your EchoMaster Pro Camera. Choose a suitable mounting place dependent on the application. Ensure that there are no wiring harnesses or hoses/pipes located behind this panel before drilling.

## Key Features

- ▶ 1/4" CMOS Sensor
- ▶ Operates at 0.5 LUX
- ▶ IP67 Rated
- ▶ 170 Degree Viewing Angle
- ▶ Selectable Image (mirrored/flipped)
- ▶ Parking Lines (selectable)

## Specification

	PCAM-110-P   PCAM-110-N	
Sensor Type	1/4" CMOS	
LEDs	0	
Illumination	0.5 LUX	
Viewing Angle	170 degrees	
Mirror Image	YES	
Normal View	YES	
Water/Debris-Proof	IP67	
Audio	NO	
Power Supply	9-16V DC	
Current	<50mA	
Working Temperature	-30°C - +70°C	
Dimensions (mm)	D (30) x W (34) x H (30)	
System	PAL	NTSC
TV Lines	480	420
Resolution	720 x 487	648 x 488

## Box Contents

- ▶ Camera
- ▶ Bracket
- ▶ Manual
- ▶ Wiring Harness
- ▶ Mounting Hardware
- ▶ Hole Saw
- ▶ RCA Barrel Adapter

## Dimensions

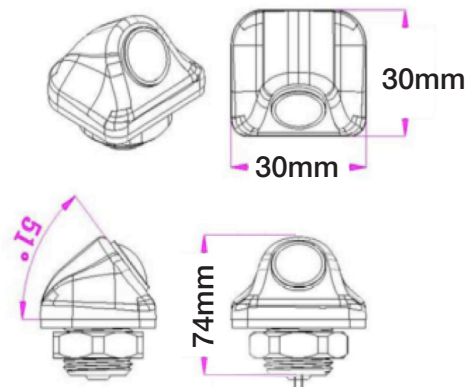

## Wiring Diagram & Pin Out

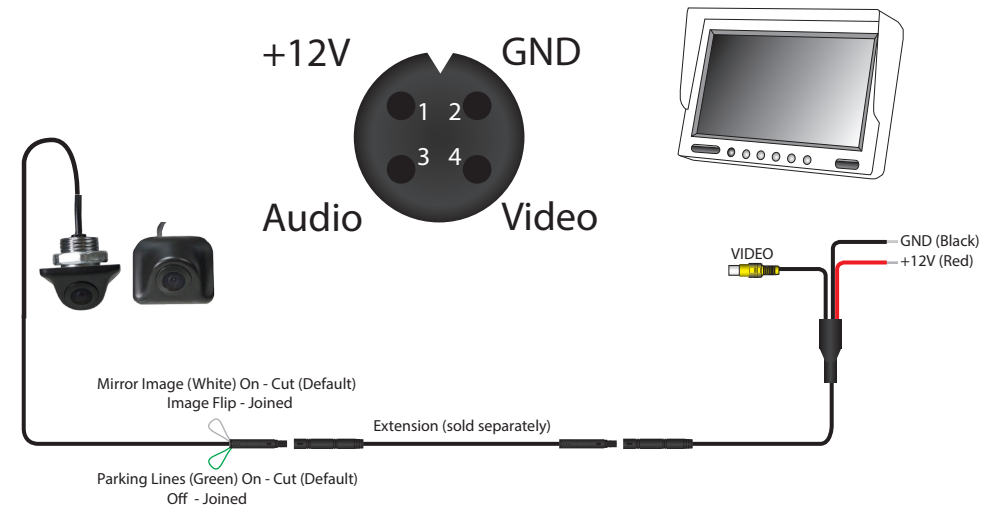

EchoMaster is a Power Brand of AAMP Global  
EchoMaster.com



15500 Lightwave Drive, Suite 202  
Clearwater, Florida 33760  
email - support@aampglobal.com (US)  
email - technical.eu@aampglobal.com (Europe)

